

Pneumatic Clamps

General Information

Pneumatic clamps have a variety of uses in machine and fixture construction. They are used for clamping, holding and positioning workpieces. The different pneumatic clamps can be categorized into the following types, based on their kinematic properties and design: Pneumatically operated toggle clamps, fastening clamps and swing clamps.

Toggle clamps

Pneumatic toggle clamps correspond to manually operated toggle clamps in terms of design and dimensions. They function according to the toggle principle but are operated purely pneumatically rather than by hand.

Due to the toggle principle, the clamp remains closed even in the event of compressed air failure.

Toggle clamps with a permanent magnet integrated in the piston (coding M) enable an end position detection via sensors.



Fastening clamps

Fastening clamps achieve high clamping forces even with small clamp sizes, which results in lower air consumption and weight reduction.

The kinematic properties of the fastening clamps are designed in such a way that the clamping force achieved in the clamping position is maintained even in the event of compressed air failure.

All fastening clamps are pre-equipped for end position detection via sensor.

On request, all fastening clamps and their accessories can be supplied with a nonstick coating for protection against welding spatter and corrosion.



Swing clamps

Swing clamps differ from other clamps in terms of their kinematic action. The clamping process consists of an initial 90° swivel stroke motion downwards, followed by the linear clamping stroke for clamping of the workpiece.

Swing clamps are usually used when the clamping point must be freely accessible from above for insertion and removal of the workpiece.

Swing clamps are typically have rectangular or cylindrical housings.

Swing clamps with rectangular housings (block style) are additionally equipped with a magnetic ring piston, and are therefore pre-fitted for end position detection via sensor.



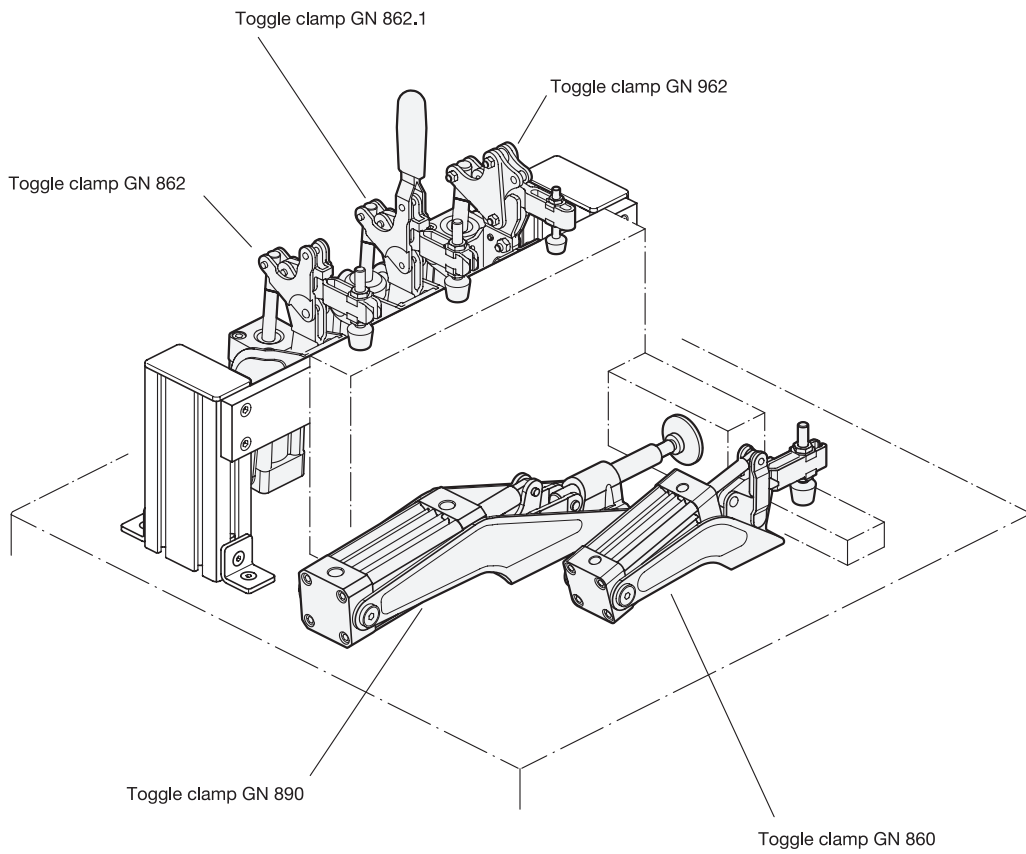

1.1

1.2

1.3

1.4

2.1

2.2

2.3

2.4



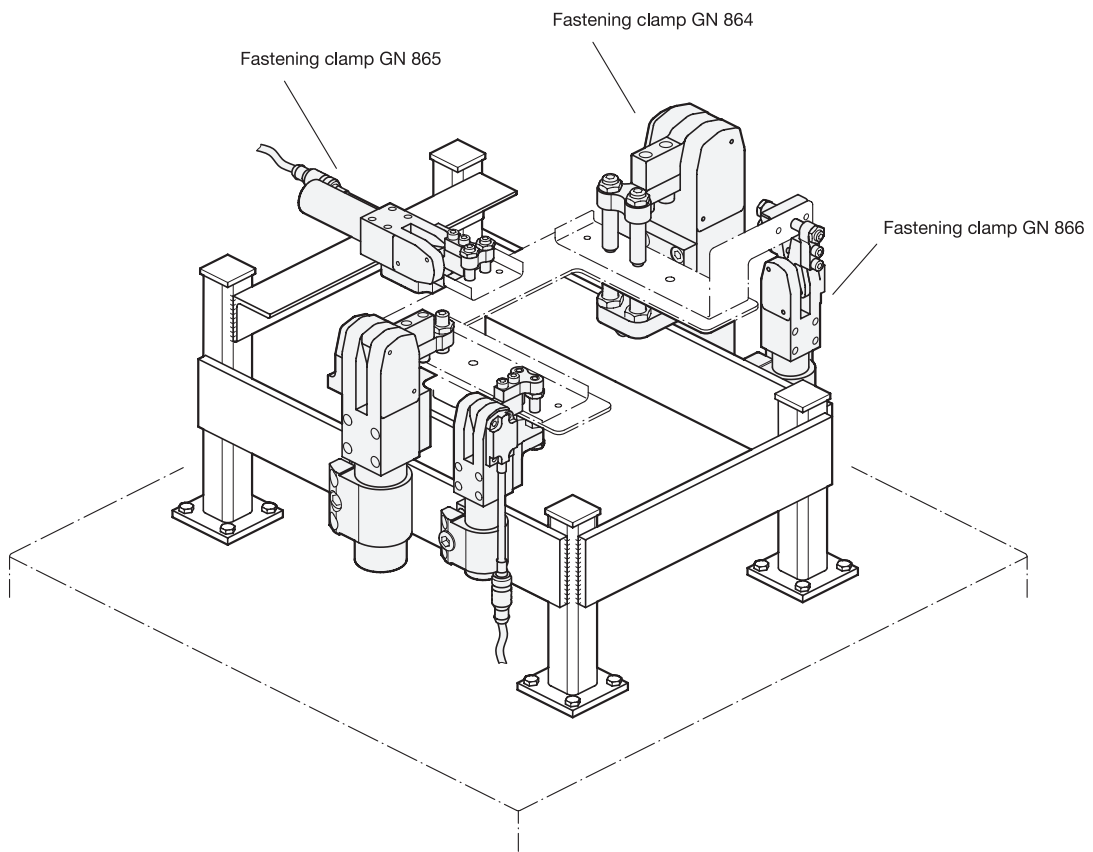

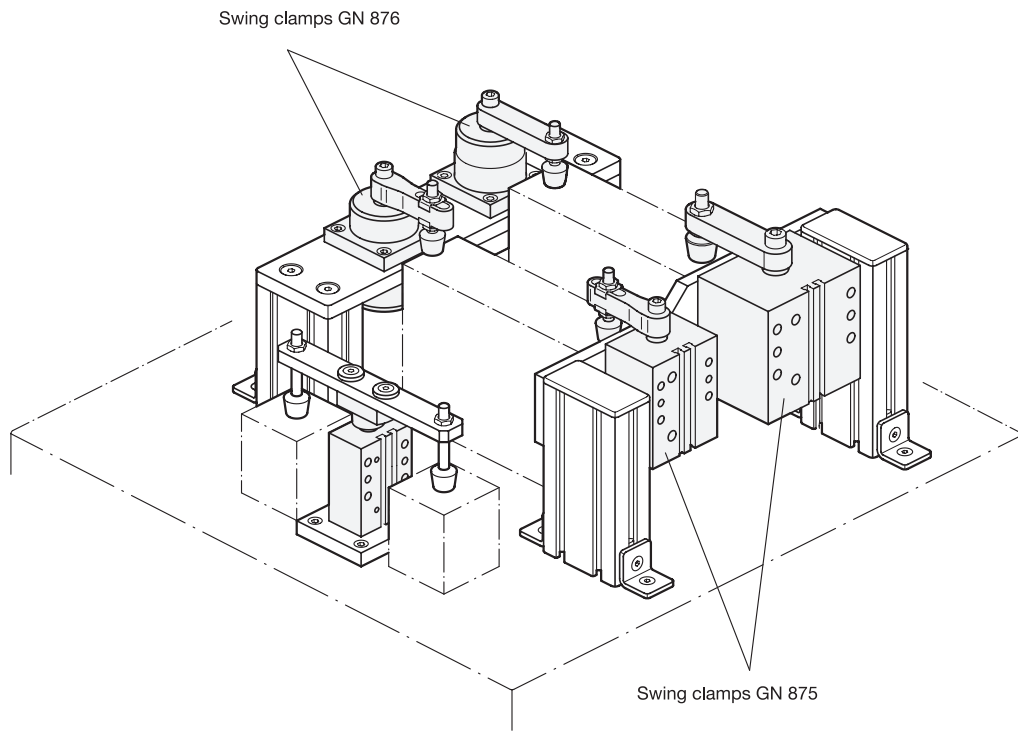

1.1

1.2

1.3

1.4



2.1

2.2

2.3

2.4

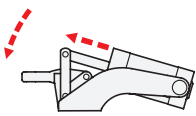
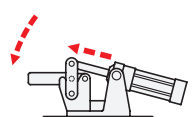
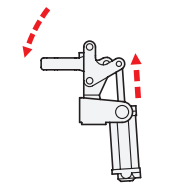
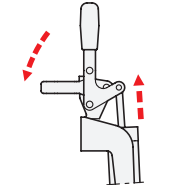
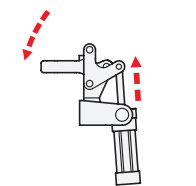

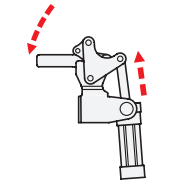
Toggle clamps				
Series	Properties	Kinematic properties	Clamping force F_s at 6 bar	Holding capacity F_H
GN 860 Page 842	<ul style="list-style-type: none"> - Toggle principle - The tensioning mechanism corresponds to the manually operated toggle clamps in terms of design - End position detection 		380 N - 3200 N 85.43 lbf - 719.39 lbf	700 N - 4000 N 157.37 lbf - 899.24 lbf
GN 861 Page 844	<ul style="list-style-type: none"> - Toggle principle - Heavy duty design with high clamping forces - End position detection 		2500 N - 3600 N 562.02 lbf - 809.31 lbf	10000 N - 20000 N 2248.09 lbf - 4496.18 lbf
GN 862 Page 846	<ul style="list-style-type: none"> - Toggle principle - Mounting via angled base - End position detection 		570 N - 1800 N 128.14 lbf - 404.66 lbf	750 N - 2600 N 168.61 lbf - 584.50 lbf
GN 862.1 Page 850	<ul style="list-style-type: none"> - Toggle principle - Mounting via angled base - Design and dimensions as GN 862, however with additional manual operation - End position detection 		1260 N - 1800 N 283.26 lbf - 404.66 lbf	2200 N - 2600 N 494.58 lbf - 584.50 lbf
GN 863 Page 852	<ul style="list-style-type: none"> - Toggle principle - Mounting via angled base - Heavy duty design with high clamping forces - End position detection 		3250 N - 5600 N 730.63 lbf - 1258.93 lbf	10000 N - 20000 N 2248.09 lbf - 4496.18 lbf
GN 890 Page 854	<ul style="list-style-type: none"> - Toggle principle - The tensioning mechanism corresponds to the manually operated push-pull type toggle clamps in terms of design - For compressive stress - End position detection 		780 N - 5520 N 175.35 lbf - 1240.95 lbf	1200 N - 25000 N 269.77 lbf - 5620.22 lbf
GN 962 Page 848	<ul style="list-style-type: none"> - Toggle principle - Mounting via angled base - Heavy duty design with high clamping forces - Long service life - End position detection 		870 N - 2280 N 195.58 lbf - 512.56 lbf	2200 N - 8500 N 494.58 lbf - 1910.88 lbf

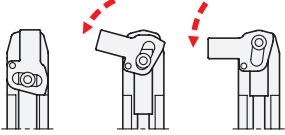
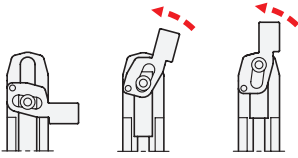
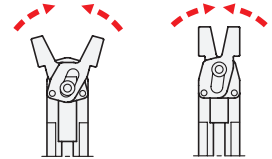
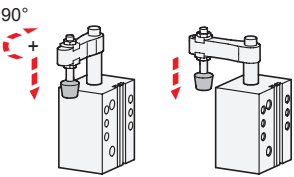
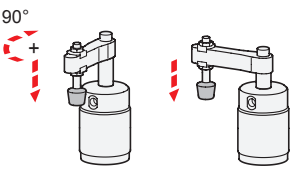
Fastening clamps				
Series	Properties	Kinematic properties	Clamping force F_s at 6 bar	Holding force F_H
GN 864 Page 866	<ul style="list-style-type: none"> - Dead point mechanism - Clamping arm for horizontal, vertical, or centered clamping - High clamping forces - Compact size - Low air consumption - Long service life - End position detection 		2220 N - 9000 N 499.08 lbf - 2023.28 lbf	4070 N - 13300 N 914.97 lbf - 2989.96 lbf
GN 865 Page 868			1250 N - 4900 N 281.01 lbf - 1101.56 lbf	2300 N - 7200 N 517.06 lbf - 1618.62 lbf
GN 866 www.jwwinco.com			630 N - 1800 N 141.63 lbf - 404.66 lbf	1150 N - 2000 N 258.53 lbf - 449.62 lbf
Swing clamps				
Series	Properties	Kinematic properties	Clamping force F_s at 6 bar	Holding force F_H
GN 875 Page 880	<ul style="list-style-type: none"> - Swivel and linear motion - Rectangular block style, universal mounting capability - Compact size - End position detection 	90° 	170 N - 1100 N 38.22 lbf - 247.29 lbf	170 N - 1100 N 38.22 lbf - 247.29 lbf
GN 876 Page 882		90° 	170 N - 1100 N 38.22 lbf - 247.29 lbf	170 N - 1100 N 38.22 lbf - 247.29 lbf

1.1
1.2
1.3
1.4
2.1
2.2
2.3
2.4

